



**3-PLEX LAND ROLLER**  
**50-60 SERIES**

**OPERATORS MANUAL**

## **LIMITED WARRANTY:**

Mandako Agri Marketing (2010) Ltd. ("MANDAKO") warrants for a period of one (1) year from the date of delivery to the purchaser that any new machinery purchased from MANDAKO (the "Product") will be free of manufacturing and materials defects (the "Covered Defects"). Before using the Product, the purchaser shall determine the suitability of the Product for its intended use. This Limited Warranty is non-transferable and valid to the purchaser of the Product only.

Except for the Covered Defects, this Limited Warranty shall not apply to any other defects or problems in the Product, including without limitation: (i) alterations, changes, replacements or repairs to the Product made by anyone other than MANDAKO or MANDAKO authorized Dealers; (ii) accessories, attachments, tools or parts sold or operated with the Product, if they have not been manufactured by MANDAKO; (iii) application or installation of accessories, attachments, tools or parts not completed in accordance with MANDAKO's operator's manual, specifications or printed instructions; (iv) defects or problems caused by misuse, abuse, neglect, improper testing, improper storage, improper handling or abnormal conditions; and (v) defects caused by wear and tear from ordinary use of the Product.

During the one (1) year warranty period, provided that written notice of the Covered Defects is given to MANDAKO within seven (7) days from the date that the defect was, or ought to have been, discovered, the liability of MANDAKO under this Limited Warranty shall be limited to the repair or replacement of any defective Product. For clarity, the purchaser shall be responsible for all expenses incurred as a result of any repairs, labour, parts, transportation or any other work, unless MANDAKO has otherwise authorized reimbursement of such expenses. In order to obtain repair or replacement, the written notice provided by the purchaser must contain full details of the Covered Defects and submitted online at [www.mandako.com/warranty-claim](http://www.mandako.com/warranty-claim) or be sent to:

Mandako  
Box 379, 12159B, Hwy 306  
Plum Coulee, Manitoba, R0G 1R0

MANDAKO reserves the right to inspect the defective Product prior to repair or replacement. If MANDAKO determines that a defect in the Product is not a Covered Defect, it shall not have any obligation to repair or replace the Product.

No one is authorized to make oral warranties or representations on behalf of MANDAKO regarding the Product. The Product is subject to design changes and MANDAKO shall not be required to retro-fit or exchange items on previously sold Product, except at its own option.

**THIS LIMITED WARRANTY IS DEEMED ACCEPTED BY YOU UPON YOUR PURCHASE OF THE PRODUCT. TO THE EXTENT PERMITTED BY LAW, THIS LIMITED WARRANTY IS EXCLUSIVE, AND IN LIEU OF ANY AND ALL OTHER WARRANTIES, CONDITIONS OR REPRESENTATIONS RESPECTING THE PRODUCT, EITHER EXPRESS OR IMPLIED, INCLUDING WITHOUT LIMITATION, ANY IMPLIED WARRANTIES OF MERCHANTABILITY, FITNESS FOR A PARTICULAR PURPOSE, NON-INFRINGEMENT, SUITABILITY, OR ANY OTHER WARRANTIES, REPRESENTATIONS OR CONDITIONS THAT MAY ARISE FROM USAGE OF TRADE OR COURSE OF DEALING.**

**MANDAKO'S OBLIGATION SHALL NOT EXTEND BEYOND THE OBLIGATIONS EXPRESSLY UNDERTAKEN ABOVE AND IN NO EVENT SHALL MANDAKO OR ITS SUPPLIERS, AGENTS, OFFICERS, DIRECTORS, CONTRACTORS AND EMPLOYEES BE LIABLE TO THE PURCHASER OR ANY THIRD PARTY FOR ANY INDIRECT, PUNITIVE, EXEMPLARY, INCIDENTAL, SPECIAL OR CONSEQUENTIAL DAMAGES OR LOSSES (INCLUDING, WITHOUT LIMITATION, DAMAGES FOR LOSS OF BUSINESS, LOSS OF PROFITS OR SALES, BUSINESS INTERRUPTION, LOSS OF BUSINESS INFORMATION, LOSS OF GOODWILL, WORK STOPPAGE, COMPUTER FAILURE OR MALFUNCTION OR ANY OTHER PECUNIARY LOSS OR COMMERCIAL DAMAGE OR LOSS) ARISING FROM ANY CLAIM WHATSOEVER, INCLUDING ANY TORT, EQUITY, NEGLIGENCE, GROSS NEGLIGENCE, WILFUL MISCONDUCT OR STRICT LIABILITY CLAIM, EVEN IF MANDAKO HAS BEEN ADVISED OF THE POSSIBILITY OF SUCH DAMAGES OR LOSSES OR THEY ARE FORESEEABLE. THE PURCHASER WAIVES ANY CLAIM AGAINST MANDAKO FOR PUNITIVE OR EXEMPLARY DAMAGES.**

**WARRANTY VOID IF NOT REGISTERED  
PLEASE REGISTER AT [www.mandako.com/registration](http://www.mandako.com/registration)**

## TABLE OF CONTENTS

Section 1: INTRODUCTION . . . . .	1
1.1 Serial Number Location . . . . .	1
Section 2: SAFETY . . . . .	3
2.1 Safety Orientation . . . . .	4
2.2 General Safety . . . . .	4
2.3 Equipment Safety Guidelines . . . . .	5
2.4 Safety Decals . . . . .	5
2:4:1 General Information . . . . .	5
2:4:2 How to Install Safety Decals . . . . .	5
2.5 Safety Training . . . . .	6
2.6 Preparation . . . . .	6
2.7 Operating Safety . . . . .	7
2.8 Maintenance Safety . . . . .	8
2.9 Tire Safety . . . . .	8
2.10 Storage Safety . . . . .	8
2.11 Hydraulic Safety . . . . .	9
2.12 Transport Safety . . . . .	9
2.13 Safety Decals . . . . .	10
2.14 Safety Decal Location . . . . .	11
Section 3: OPERATION . . . . .	13
3.1 Machine Components . . . . .	14
3.2 Machine Break-In . . . . .	18
3.3 Pre-Operation Checklist . . . . .	18
3.4 Equipment Matching . . . . .	19
3.5 Attaching/Unhooking . . . . .	20
3:5:1 Attaching to a 3-Plex Land Roller to a Pickup. . . . .	20
3:5:2 Attaching to a 3-Plex Land Roller to a Tractor. . . . .	22
3.6 Connect the Hydraulic and Electrical System . . . . .	23
3.7 Field Operation . . . . .	24
3:7:1 Starting . . . . .	24
3:7:2 Stopping . . . . .	24
3:7:3 Roller Weight . . . . .	24
3:7:4 Ballasting . . . . .	25
3:7:5 Soil Moisture . . . . .	25
3:7:6 Hitch Type . . . . .	26
3:7:7 Hitch Height . . . . .	26
3:7:8 Travel Speed . . . . .	26
3:7:9 Turning (Cornering) Speed . . . . .	27
3:7:10 Operating Hints . . . . .	27
3.8 Transport to Field Conversion . . . . .	29
3.9 Transporting . . . . .	32
3.10 Storage . . . . .	34
3:10:1 Place in Storage . . . . .	34
3:10:2 Remove from Storage . . . . .	35
Section 4: SERVICE AND MAINTENANCE . . . . .	37
4.1 Fluids and Lubricants . . . . .	37
4:1:1 Grease . . . . .	37
4:1:2 Storing Lubricants . . . . .	37
4:1:3 Greasing . . . . .	37
4.2 Servicing Intervals . . . . .	38

**TABLE OF CONTENTS, cont'd**

4:2:1 Every 10 Hours or Daily . . . . .	38
4:2:2 Monthly or Every 1000 Acres . . . . .	38
4:2:3 Annually or Every 3000 Acres . . . . .	39
4.3 Service Record. . . . .	40
Section 5: TROUBLE SHOOTING . . . . .	41
Section 6: SIGN-OFF FORM . . . . .	43
Section 7: REFERENCE. . . . .	45
7.1 Bolt Torque . . . . .	45
7.2 Tire Pressure . . . . .	46
7.3 Hydraulic Fitting Torque. . . . .	46
7.4 Mechanical Specifications . . . . .	47



## Section 1: INTRODUCTION

Congratulations on your choice of a Mandako 3-Plex Land Roller to compliment your farming operation. This equipment has been designed and manufactured to meet the needs of a discerning agricultural industry.

Safe, efficient and trouble free operation of your Mandako 3-Plex Land Roller requires that you and anyone else who will be using or maintaining the 3-Plex Land Roller, read and understand the Safety, Operation, Maintenance and Trouble Shooting information contained within this Operator's Manual.

This manual covers all sizes of the Mandako 3-Plex Land Roller. Keep this manual handy for frequent reference and to pass on to new operators or owners. Call your Mandako dealer if you need assistance, information or additional copies of the manual.

**NOTE:**

The directions left, right, front and rear, as mentioned throughout this manual, are as seen from the tractor driver's seat and facing in the direction of travel.

### 1.1 SERIAL NUMBER LOCATION



Fig. 1 Model/Serial Number Location

Always give your dealer the serial number of your 3-Plex Land Roller when ordering parts or requesting service or other information.

The serial number plate is located where indicated above. Please mark the number in the space provided for easy reference.

Model Number \_\_\_\_\_

Serial Number \_\_\_\_\_

Page intentionally left blank

## Section 2: SAFETY

Why is SAFETY important to you?

3 Big Reasons:

- ▲ Accidents Disable and Kill
- ▲ Accidents Cost
- ▲ Accidents Can Be Avoided

This Safety Alert symbol means:  
ATTENTION!  
BECOME ALERT!  
YOUR SAFETY IS INVOLVED!



The Safety Alert symbol identifies important safety messages on the 3 Plex Land Roller and in this manual.

When you see this symbol, be alert to the possibility of personal injury or death.

Follow the instructions in the safety message.

### SIGNAL WORDS:

Note the use of the signal words DANGER, WARNING, CAUTION and ATTENTION along with the accompanying safety messages. The appropriate signal word for each message has been selected using the following guidelines:

### **DANGER**

DANGER - Indicates an imminently hazardous situation which, if not avoided, will result in death or serious injury.

This signal word is to be limited to the most extreme situations typically for machine components which, for functional purposes, cannot be guarded.

### **WARNING**

WARNING - Indicates a potentially hazardous situation which, if not avoided, could result in death or serious injury.

It identifies hazards that are exposed when guards are removed. It may also be used to alert against unsafe practices.

### **CAUTION**

CAUTION - Indicates a potentially hazardous situation which, if not avoided, may result in minor or moderate injury.

It may also be used to alert against unsafe practices.

### **ATTENTION**

ATTENTION - Indicates practices or situations which may result in the malfunction of, or damage to, the equipment.



## 2.1 SAFETY ORIENTATION

You are responsible for the SAFE operation and maintenance of your Mandako 3-Plex Land Roller. Ensure that you and anyone else who will use, maintain or work around the 3-Plex Land Roller be familiar with the Safety, Operating and Maintenance procedures in this manual.

This manual will take you step-by-step through your working day and alerts you to all good safety practices that should be used while operating the 3-Plex Land Roller.

Remember, you are the key to safety. Good safety practices not only protect you but also the people around you. Make these practices a working part of your safety program. Be certain that everyone using this equipment follows all safety precautions, as well as the detailed operating and maintenance procedures.

Most accidents can be prevented. Do not risk injury or death by ignoring good safety practices:

- 3-Plex Land Roller owners must give operating instructions to operators or employees before allowing them to operate the machine, and review annually thereafter.
- The most important safety device on this equipment is a SAFE operator. It is the operator's responsibility to read and understand ALL Safety and Operating instructions in the manual and to follow them. Most accidents can be avoided.
- A person who has not read and understood all operating and safety instructions is not qualified to use the machine. An untrained operator exposes himself and bystanders to the possibility of serious injury or death.
- Do not modify the equipment in any way. Unauthorized modification may impair the function and/or safety and could affect the life of the equipment.
- Think SAFETY! Work SAFELY!

## 2.2 GENERAL SAFETY

- Read and understand the Operator's Manual and all safety signs before using, maintaining, adjusting or cleaning the 3-Plex Land Roller.



- Have a first-aid kit available for use should the need arise and know how to use it.



- Have a fire extinguisher available for use should the need arise and know how to use it.

- Do not allow riders.

- Wear appropriate protective gear. This list includes but is not limited to:

- Hard hat
- Protective shoes with slip resistant soles
- Protective glasses, goggles or face shield
- Heavy gloves
- Hearing Protection



- Install and secure all guards before starting.

- Wear suitable ear protection for prolonged exposure to excessive noise.





- Lower machine to ground, place all controls in neutral, set park brake, stop engine, remove ignition key and wait for all moving parts to stop before servicing, adjusting, repairing or unplugging.

- Clear the area of people, especially small children, before operating the unit.

- Review safety related items annually with all personnel who will be operating or maintaining the 3-Plex Land Roller.

## 2.3 EQUIPMENT SAFETY GUIDELINES

- Safety of the operator and bystanders is one of the main concerns in the design and development of equipment. However, every year many accidents occur, which could have been avoided, by a few seconds of thought and a more careful approach to handling equipment.
- You, the operator, can avoid many accidents by following the precautions in this section. Insist that those working with you, or for you, follow them also.
- In order to provide a better view, certain photographs or illustrations in this manual may show an assembly with a safety shield removed. Equipment should never be used in this condition. Keep all shields in place. If shield removal becomes necessary for repairs, replace the shield prior to use. 
- Replace any safety or instructional signs that are missing or illegible. The location of these safety signs are indicated in this manual.
- Never use alcoholic beverages or drugs which can hinder alertness or coordination while using this equipment. Consult your doctor about using this machine while taking prescription medications.
- Under no circumstances should young children be allowed to work with this equipment.
- The operator should be a responsible, properly trained and physically able person. They should be familiar with machinery and trained in this equipment's operations.
- If the elderly are assisting with work, their physical limitations need to be recognized and accommodated.
- If the tow vehicle is a tractor, it should be equipped with a Roll Over Protective Structure (ROPS) and a seat belt. 
- Never exceed the limits of the 3-Plex Land Roller. If its ability to do a job, or to do so safely, is in question - DON'T TRY IT.
- Do not modify the equipment in any way. Unauthorized modification may impair the function and life of the equipment, and may result in serious injury or death.

## 2.4 SAFETY DECALS

### 2:4:1 General Information:

- Keep safety decals clean and legible at all times.
- Replace decals that are missing or have become illegible.
- Replaced parts that displayed a safety decal should also display the current sign.
- Safety decals displayed in Section 2.13 each have a part number located below the sign. Use this part number when ordering replacements.
- Safety decals are available from your authorized Distributor or Dealer Parts Department.

#### NOTE:

Call Mandako directly if you are unfamiliar with who your local Dealer/Distributor is.



### 2:4:2 How to Install Safety Decals:

1. Be sure that the installation area is clean and dry.
2. Be sure temperature is above 50°F (10°C).
3. Determine exact position before you remove the paper backing. (See Section 2.13)
4. Remove the smallest portion of the split backing.
5. Align the decal over the specified area and carefully press the small portion with the exposed adhesive in place.
6. Slowly peel back the remaining paper and carefully smooth the rest of the decal in place.
7. Small air pockets can be pierced with a pin and smoothed out using the piece of the paper backing.

## 2.5 SAFETY TRAINING

- Safety is a primary concern in the design and manufacture of our products. Unfortunately, our efforts to provide safe equipment can be wiped out by a single careless act of an operator or bystander. 
- Accident prevention and identifying hazards are dependent upon the proper training of personnel. Their awareness, concern and common sense are crucial when involved with the operation, transport, maintenance and storage of the equipment.
- Working with unfamiliar equipment can lead to careless injuries. Read this manual to become acquainted with the machine.
- Whether the machine owner is the operator, loans or rents it out, it is their responsibility to make certain that the borrower reads and understands the operator's manuals.
- Know your controls, how to stop the tow unit, the engine, and machine quickly in an emergency.
- Train all new personnel and review instructions frequently with existing workers. Be certain only a properly trained and physically able person will use the machinery.
- A person who has not read and understood all operating and safety instructions is not qualified to use the machine. An untrained operator exposes himself and bystanders to the possibility of serious injury or death.
- If the elderly are assisting with the work, their physical limitations need to be recognized and accommodated.

## 2.6 PREPARATION

- Never use the 3-Plex Land Roller until you have read this Manual, and the tow unit's Operator's Manual. Take note of each Safety Message found on the safety decals on the 3-Plex Land Roller and the tow vehicle. 
- Personal protective equipment including a hard hat, safety glasses, safety shoes and gloves are recommended during assembly or installation, operation, adjustment, maintaining or repairing, cleaning or moving the unit. 
- Do not allow long hair, loose fitting clothing or jewelry to be around equipment.
- **PROLONGED EXPOSURE TO LOUD NOISE MAY CAUSE PERMANENT HEARING LOSS!**
- Power equipment with or without equipment attached can often be noisy enough to cause permanent or partial hearing loss. We recommend that you wear hearing protection on a full-time basis if the noise in the Operator's position exceeds 80db. 
- Noise over 85db on a long-term basis can cause severe hearing loss. Noise over 90db adjacent to the Operator over a long-term basis may cause permanent, total hearing loss.

### NOTE:

Hearing loss from loud noise (from tractors, chain saws, radios, and other such sources close to the ear) is cumulative over a lifetime without hope of natural recovery.

- Any tractor used to tow the 3-Plex Land Roller must be equipped with an approved Roll-Over-Protective-Structure (ROPS). Always wear a seat belt. Serious injury or even death could result from falling off the tractor. If a roll-over occurs, the operator could be pinned under the ROPS or inside the tractor.



- If a pickup truck is used as the tow vehicle, be sure the unit is properly hitched to the truck. Be sure to use safety chains to prevent unplanned separation. Cross the chains under the hitch to support the hitch should unplanned separation occur.
- Clear working area of stones, branches or hidden obstacles that might be hooked or snagged, causing damage or injury.
- Be sure the machine is properly attached, adjusted and in good operating condition.
- Ensure that all safety shielding and safety decals are properly installed and in good condition.

### 2.7 OPERATING SAFETY

- Read and understand the Operator's Manual and all safety signs before using. Review safety instructions annually.



- Lower machine to the ground, place all controls in neutral, stop engine, set park brake, remove ignition key, and wait for all moving parts to stop before servicing, adjusting, repairing or unplugging.
- Install and secure all guards and shields before starting or operating.
- Keep hands, feet, hair and clothing away from all moving and/or rotating parts.
- Do not allow riders on the 3-Plex Land Roller or tow vehicle during operation or transporting.
- Clear the area of all bystanders, especially children, before starting.



- Stay away from all frames and components when folding or extending. Keep others away.



- Clean reflectors, SMV (Slow Moving Vehicle) emblem and lights before transporting. Be sure you are in compliance with all federal and local regulations regarding transport of equipment on public roads and highways.
- Install cylinder stops/transport lock brackets and close ball valves in hydraulic lines before transporting or working under the frame.
- Do not exceed a safe travel speed.
- Use hazard flasher on tow vehicle when transporting.
- Before applying pressure to the hydraulic system, make sure all components are tight and that steel lines, hoses and couplings are in good condition.
- If a pickup truck is used as the tow vehicle be sure the 3-Plex Land Roller is properly hitched to the truck. Be sure and use the safety chains to prevent unplanned separation. Cross the chains under the hitch to support the hitch should unplanned separation occur.
- It is recommended that only 3/4 tonne or larger capacity trucks be used for towing on the road. This size of truck plus careful driving will provide recommended stability and control when towing.
- Always refer to the towing vehicle owner's manual trailer towing section to determine the vehicle's towing capacity and to ensure compatibility and maximum safety.
- Shift towing unit to a lower gear before going down steep down-grades to use engine as retarding force. Keep towing vehicle in gear at all times.
- Attach securely to towing unit using a hardened pin with a retainer and a safety chain.
- Review safety instructions annually.
- Do not drink and drive.

## 2.8 MAINTENANCE SAFETY

- Good maintenance is your responsibility. Poor maintenance is an invitation for trouble.
- Follow good shop practices.
  - Keep service area clean and dry.
  - Be sure electrical outlets and tools are properly grounded.
  - Use adequate light for the job at hand.
- Lower machine to the ground. Place all controls in neutral, stop engine, set the park brake, remove ignition key, and wait for all moving parts to stop before servicing, adjusting, repairing or unplugging.



- Place stand or blocks under the frame before working beneath the machine or when changing tires.

- Always use personal protective equipment such as safety glasses, gloves and hearing protection, when performing any service or maintenance work.



- Where replacement parts are necessary for periodic maintenance and servicing, genuine factory replacement parts must be used to restore your equipment to original specifications.

- A fire extinguisher and first aid kit should be kept readily accessible while performing maintenance on this equipment.



- Relieve pressure on the hydraulic system before servicing or disconnecting from tractor.

- Before applying pressure to a hydraulic system, make sure all components are tight and that steel lines, hoses and couplings are in good condition.

- When completing a maintenance or service function, make sure all safety shields and devices are installed before placing unit in service.



## 2.9 TIRE SAFETY



- Failure to follow proper procedures when mounting a tire on a wheel or rim can produce an explosion which may result in serious injury or death.
- Do not attempt to mount a tire unless you have the proper equipment and experience to do the job.
- Have a qualified tire dealer or repair service perform required tire maintenance.
- When replacing worn tires, make sure they meet the original tire specifications. Never under size.



## 2.10 STORAGE SAFETY

- Store the unit in an area away from human activity
- Store the unit in a dry, level area. Support the frame with planks if required.
- Place the machine into its transport configuration relieve the pressure from off the Wheel Lift Cylinder and onto the Cylinder Stops  
or  
rest the Roller Drums on the ground in field configuration to relieve the pressure in the hydraulic circuit.
- Do not allow children to play on or around the stored machine.

## 2.11 HYDRAULIC SAFETY

- Always place all tractor hydraulic controls in neutral before dismounting.
- Make sure that all components in the hydraulic system are kept in good condition and are clean.
- Replace any worn, cut, abraded, flattened or crimped hoses and steel lines.
- Relieve pressure from hydraulic circuit before servicing or disconnecting from tractor.
- Do not attempt any makeshift repairs to the hydraulic lines, fittings or hoses by using tape, clamps or cements. The hydraulic system operates under extremely high-pressure, such repairs will fail suddenly and create a hazardous and unsafe condition.
- Wear proper hand and eye protection when searching for a high-pressure hydraulic leak. Use a piece of wood or cardboard as a backstop instead of hands to isolate and identify a leak. 
- If injured by a concentrated high-pressure stream of hydraulic fluid, seek medical attention immediately. Serious infection or toxic reaction can develop from hydraulic fluid piercing the skin surface. 
- Before applying pressure to the system, make sure all components are tight and that lines, hoses and couplings are in good condition.

## 2.12 TRANSPORT SAFETY

- Read and understand ALL the information in the Operator's Manual regarding procedures and SAFETY when operating the 3-Plex Land Roller in the field and/or on the road. 
- Maintain wheel bolts to specified torque.
- Do not raise the frame or transport with fluid in the Roller Drums.
- Check with local authorities regarding 3-Plex Land Roller transport on public roads. Obey all applicable laws and regulations.

- Always travel at a safe speed. Use caution when making corners or meeting traffic.
- Clean reflectors, SMV (Slow Moving Vehicle) emblem and all the lights before transporting. Be sure you are in compliance with all federal and local regulations regarding transport of equipment on public roads and highways. 
- Install additional lights on the rear of the machine to safeguard against rear end collisions. Daybreak and dusk are particularly dangerous and pilot vehicles are recommended.
- Be sure that the machine is securely hitched to the towing vehicle and a retainer is used through the drawbar pin. Always attach a safety chain between the frame and the towing machine. Cross chains under the hitch to support hitch should unplanned separation occur.
- Install cylinder stops/transport lock brackets and close valves in hydraulic lines before transporting or working under the frame.
- It is recommended that only 3/4 tonne or larger capacity trucks be used for towing on the road. This size of truck plus careful driving will provide recommended stability and control when towing.
- Always refer to the towing vehicle owner's manual trailer towing section to determine the vehicles towing capacity and to ensure compatibility and maximum safety.
- Keep to the right and yield the right-of-way to allow faster traffic to pass. Drive on the shoulder of the road, if permitted by law.
- Do not exceed 32 km/h (20 mph) on highway transport. Reduce speed on rough roads and surfaces.
- Always use hazard warning flashers on tow vehicle when transporting unless prohibited by law.
- Shift towing unit to a lower gear before going down steep down-grades to use engine as retarding force. Keep towing vehicle in gear at all times.
- Do not drink and drive.

## 2.13 SAFETY DECALS

The various safety decals, and their locations on the equipment are shown in the illustrations to follow.

Good safety practices require familiarizing yourself with the decals. Read the warning messages, and note the area, or particular function related to that area, that the decal highlights.

If safety decals have been damaged, removed, become illegible, or replacement parts do not have the decal; new ones must be applied. Safety decals are available from your authorized dealer.

Mandako reserves the right to update safety decals without notice. Safety decals may not be to scale or exactly as shown.



# WARNING

**TO PREVENT SERIOUS INJURY OR DEATH:**

- Read and understand the Operator's Manual and all safety signs before using. Review safety instructions annually.
- Place all controls in neutral, stop tractor engine, set park brake and wait for all moving parts to stop before servicing, adjusting, repairing or unplugging implement.
- Install and secure all guards and sheilds before starting or operating.
- Keep hands, feet, hair and clothing away from all moving and / or rotating parts.
- Do not allow riders on the implement or tractor during operation or transportation.
- Stay away from all extending or folding frames and components. Keep others away.
- Ensure reflectors, SMV and lights are clean and visible before transporting. Be sure lights are working.

- Stay away from overhead power lines when folding or extending frames and components. Electrocutation can occur without direct contact.
- Attach to towing unit securely using a hardened pin with retainer and a safety chain.
- Do not exceed a safe travel speed.
- Use hazard flashers on tractor when transporting.
- Before applying pressure to the hydraulic system, make sure all components are tight and that steel lines, hoses and couplings are in good condition.
- When repairing or servicing implement, refer to Operator's Manual.



R9913114

Part No. R9913114



# WARNING

COLLISION HAZARD

**TO PREVENT SERIOUS INJURY OR DEATH:**

**Do not exceed 32 KPH  
(20 MPH)**

**Slow down for corners and rough terrain.**

R9913073

Part No. R9913073

# ATTENTION

CHECK AND RE-TORQUE LUG NUTS BEFORE & AFTER EVERY 50 MILES

R9913103

Part No. R9913103

Remember - Safety Decals are for your protection! If they have been damaged, removed, become illegible, or replacement parts do not have the decal; new ones must be applied. Safety decals are available from your authorized dealer.

<b>WARNING</b>	
	<p style="text-align: center;"><b>COLLISION HAZARD</b></p> <p><b>TO PREVENT INJURY, DEATH OR DAMAGE TO THE MACHINE:</b></p> <ul style="list-style-type: none"> <li>- Close cylinder hydraulic ball valves before transporting or working under frame.</li> </ul> <p style="text-align: right; font-size: small;">R9913111</p>

Part No. R9913111

<b>WARNING</b>	
	<p style="text-align: center;"><b>HIGH PRESSURE FLUID HAZARD</b></p> <p><b>TO PREVENT SERIOUS INJURY OR DEATH FROM HIGH PRESSURE FLUID:</b></p> <ul style="list-style-type: none"> <li>- Relieve pressure on system before repairing or adjusting.</li> <li>- Wear proper hand and eye protection when searching for leaks. Use wood or cardboard instead of hands.</li> <li>- Keep all components in good repair.</li> </ul> <p style="text-align: right; font-size: small;">R9913110</p>

Part No. R9913110

<b>WARNING</b>	
	<p style="text-align: center;"><b>CRUSHING HAZARD</b></p> <p><b>TO PREVENT SERIOUS INJURY:</b></p> <ul style="list-style-type: none"> <li>- Stay clear of moving parts.</li> </ul> <p style="text-align: right; font-size: small;">R9913113</p>

Part No. R9913113

<b>WARNING</b>	
	<p style="text-align: center;"><b>COLLISION HAZARD</b></p> <p><b>TO PREVENT SERIOUS INJURY, DEATH OR DAMAGE TO THE MACHINE:</b></p> <ul style="list-style-type: none"> <li>- Install cylinder stops over wheel lift cylinder rods before transporting, storing or working under frame.</li> </ul> <p style="text-align: right; font-size: small;">R9913043</p>

Part No. R9913043

### 2.14 SAFETY DECAL LOCATION

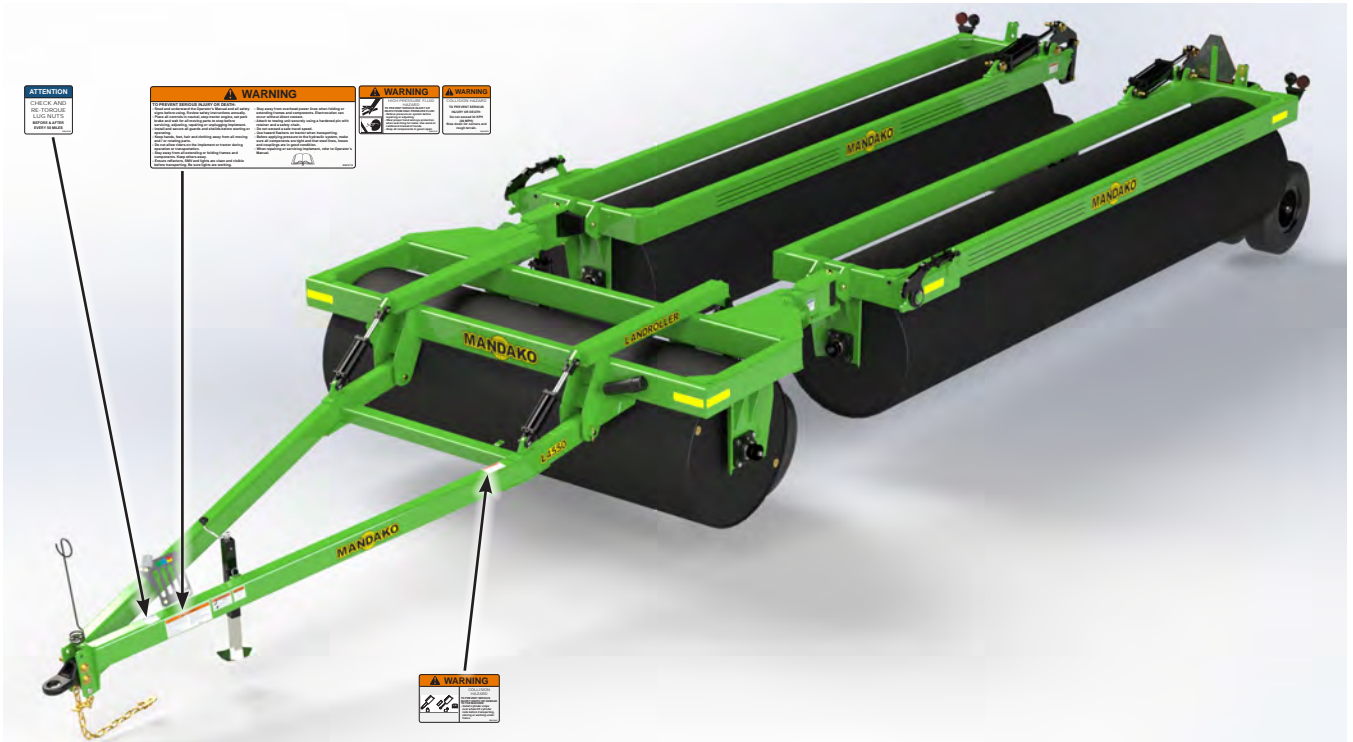

Fig. 2 Hitch Decals



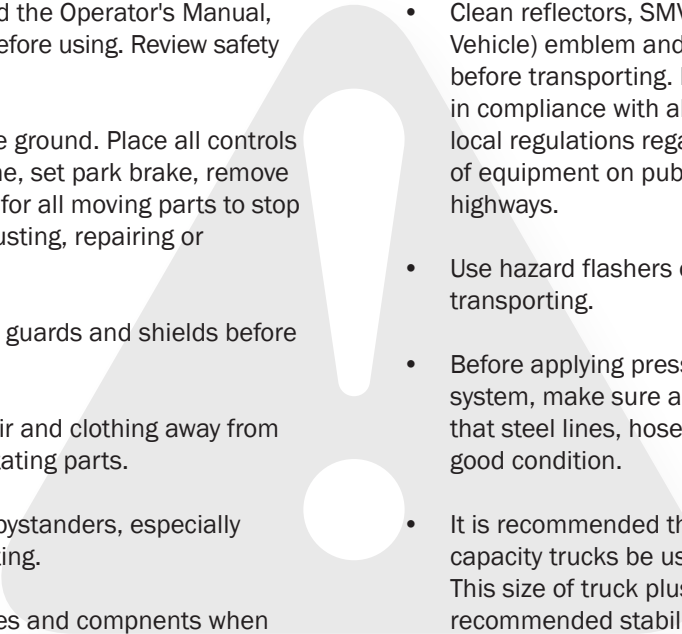

Fig. 3 Rear Decals



Fig. 4 Mid Section Decals

### Section 3: OPERATION

- 
- 
- Read and understand the Operator's Manual, and all safety signs before using. Review safety instructions annually.
  - Lower machine to the ground. Place all controls in neutral, stop engine, set park brake, remove ignition key and wait for all moving parts to stop before servicing, adjusting, repairing or unplugging.
  - Install and secure all guards and shields before starting or operating.
  - Keep hands, feet, hair and clothing away from all moving and/or rotating parts.
  - Clear the area of all bystanders, especially children, before starting.
  - Stay away from frames and components when folding or extending wings. Keep others away.
  - Install cylinder stops/transport lock brackets and close valves in hydraulic lines before transporting or working under the frame.
  - Attach securely to towing unit using a hardened pin with a retainer and a safety chain.
  - Do not allow riders on the 3-Plex Land Roller or tow unit during operation or transporting.
  - Clean reflectors, SMV (Slow Moving Vehicle) emblem and all the lights before transporting. Be sure you are in compliance with all federal and local regulations regarding transport of equipment on public roads and highways.
  - Use hazard flashers on tow unit when transporting.
  - Before applying pressure to the hydraulic system, make sure all components are tight and that steel lines, hoses and couplings are in good condition.
  - It is recommended that only 3/4 tonne or larger capacity trucks be used for towing on the road. This size of truck plus careful driving will provide recommended stability and control when towing.
  - Shift towing unit to a lower gear before going down steep down-grades to use engine as retarding force. Keep towing vehicle in gear at all times.
  - Do not drink and drive.
  - Do not exceed 32 km/h (20 mph) on highway transport. Reduce speed on rough roads and surfaces.
- 

It is the responsibility of the owner and operator to read this manual. They must train all others before starting to work with the machine. Follow all safety instructions exactly. Safety is everyone's business. By following recommended procedures, a safe working environment is provided for the operator, bystanders and the area around the work site.

Many features incorporated into this machine are the result of suggestions made by customers like you.

This manual will describe how to set the 3-Plex Land Roller to provide maximum field efficiency. By following the operating instructions in conjunction with a good maintenance program, your 3-Plex Land Roller will provide many years of trouble-free service.

### 3.1 MACHINE COMPONENTS

The Mandako 3-Plex Land Roller consists of a 3 section frame with a large roller mounted in each frame. Each wing section hinges at the center section frame to fold out for field operation or fold in for transport operation.

Two sets of wheel assemblies on the center section support the center section for transport. A rear steering wheel assembly on the outboard of each wing frame support the wings for transport and directs the wings when folding in or out.

All 3-Plex Land Rollers come standard with rear steering wheel assemblies to assist the folding in and out action. The hydraulic circuit for the rear steering wheel assemblies is linked to the wing lock hooks. When the rear wheels are turned to fold out the unit, the wing lock hooks are in an open position allowing the frames to connect. When the wing lock hooks are in the closed/locked position the rear steering wheel assemblies are turned straight. These hydraulic circuits can also be operated separately by using the hydraulic ball valves.

U-shaped cylinder stops/transport lock brackets are provided at each wheel assembly to install on the lift cylinders for storage, transport or while working under the

frame. Cylinders on the hitch are used to set the angle/height/position of the hitch. A hydraulic ball valve in the circuit can be opened or closed as required for operation or transport.

The main components of the unit are as follows:

- a. Hitch
- b. Center Section
- c. Right Wing
- d. Left Wing
- e. Wheel Assemblies
- f. Rear Steering Wheel Assemblies
- g. Wheel Lift Cylinders
- h. Cylinder Stops/Transport Lock Brackets
- i. Hitch Jack
- j. Hydraulic Hose Retainer
- k. Hydraulic Hose Storage Plate
- l. Hydraulic Ball Valve
- m. Wing Lock Hooks
- n. Operators Manual Cannister
- o. Hydraulic Couplers/Male Tips
- p. Roller Drums
- q. Storage Rod Holder



Fig. 5 Components (Transport Mode)



Fig. 6 Components (Field Mode)



Fig. 7 Hitch Components



Fig. 8 Rear Components



Fig. 9 Center Section Components



Fig. 10 Center Section Components

## 3.2 MACHINE BREAK-IN

There are no operational restrictions on the 3-Plex Land Roller when used for the first time.

Although, it is recommended that the following mechanical items be checked:

### After operating for 1/2 hour:

1. Re-torque all wheel bolts.
2. Re-torque all fasteners and hardware.
3. Check that no hydraulic lines are being pinched or crimped. Re-route as required.
4. Inspect all hydraulic lines, hoses, fittings and couplers for leaks. Tighten any leaking fittings.
5. Check for, and remove all entangled material.
6. Lubricate all grease fittings with one shot of grease.

### NOTE:

See Section 7 for specifications

### After 5 hours and 10 hours of operation:

7. Re-torque all wheel bolts, fasteners and hardware.
8. Inspect all hydraulic lines, hoses, fittings and couplers for leaks. Tighten any leaking fittings.
9. Go to the normal servicing and maintenance schedule as defined in the Service and Maintenance Section.

## 3.3 PRE-OPERATION CHECKLIST

Efficient and safe operation of the Mandako 3-Plex Land Roller requires that each operator reads the manual. They must understand the procedures, and all related safety precautions.

A pre-operation checklist is provided for the operator. It is important for personal safety, and to maintain the good mechanical condition of the 3-Plex Land Roller that this checklist is followed.

Before operating the 3-Plex Land Roller and each time thereafter, the following areas should be checked off:

1. Lubricate the machine according to the schedule outline in the Section 4.2.
2. Use a tractor of adequate power and weight to operate the 3-Plex Land Roller. See Section 3.4 for recommendations.
3. Be sure that the 3-Plex Land Roller is properly hitched to the tow vehicle. Use a hardened drawbar pin with a retainer. Attach safety chains.
4. Inspect all hydraulic lines, hoses, fittings and couplers for leaks. Tighten any leaking fittings.
5. Check the tires. Ensure they are inflated to their specified pressure.
6. Check the wheel bolts. Ensure they are tightened to their specified torque.
7. Remove all entangled material.
8. Be sure that all lights, reflectors and SMV (Slow Moving Vehicle) emblem required by the local highway authorities are installed, clean and in good working order.

## 3.4 EQUIPMENT MATCHING

To ensure the safe and reliable operation of the 3-Plex Land Roller, it is necessary to use a tractor with appropriate specifications.

As a guideline, be certain that these requirements are met:

1. **Horsepower:**  
The 3-Plex Land Roller needs both power and mass to pull and stabilize the unit in all operating conditions.

The lower levels of power are appropriate for hard, level terrain. Higher levels for soft or hilly land. Extra mass is also required to maintain stability when slowing down or travelling downhill.

2. **Hydraulic System:**  
The tractor's hydraulic system must be capable of 5 gpm (19 lpm) at 2800 psi (19,320 kPa).

All 3-Plex Land Rollers require 3 hydraulic circuits. One circuit to operate the wheel lift cylinders, another to adjust the hitch and one circuit to function the rear steering wheel assemblies and wing lock hooks.



Fig. 11 3-Plex Land Roller

Size	Recommended Tractor Horsepower
30	120+
34	136+
40	160+
42	168+
45	180+
50	200+
60	240+

Table 1 - Horsepower Recommendation



Fig. 12 Hydraulic Circuit Legend



### 3.5 ATTACHING/UNHOOKING

The 3-Plex Land Roller can be attached to a pickup truck or a tractor depending on the application. Since the 3-Plex Land Roller generates a vertical load on the hitch, care must be taken to properly attach the tow vehicle.

#### 3:5:1 ATTACHING A 3-PLEX LAND ROLLER TO A PICKUP

Follow this procedure when attaching the 3-Plex Land Roller to a pickup truck.

1. Ensure all bystanders, especially small children, are clear of the working area.
2. Make sure there is enough room and clearance to safely back up to the 3-Plex Land Roller.
3. Use the Jack to move the hitch to the required height.
4. Slowly back the tow vehicle until the clevis and hitch are aligned.
5. Lower the hitch into position.
6. Install safety pin or locking bolt. Tighten to its specified torque.



Fig. 13 Clear Working Area



Fig. 14 Aligning



Fig. 15 Hitch Lowered

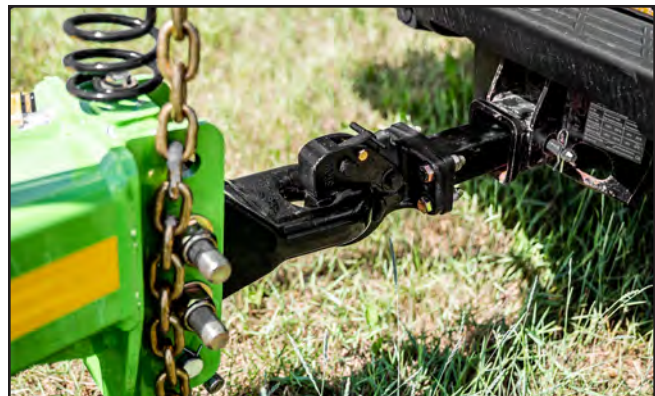

Fig. 16 Lock Pin/Bolt

7. Attach the safety chain to the pickup truck frame to prevent unexpected separation.



Fig. 17 Safety Chain

8. Connect the wiring harness plug to the pickup truck outlet. Always use the optional adapter to convert 7-pin terminal to plug on pickup truck if necessary.



Fig. 18 Wiring Harness

9. Retract the jack.
  - Pull out the pin.
  - Rotate 90° and store in stowed position.
  - Install the pin.



Fig. 19 Jack Stowed

## 3:5:2 ATTACHING A 3-PLEX LAND ROLLER TO A TRACTOR

Follow this procedure when attaching the 3-Plex Land Roller to a tractor.

1. Ensure all bystanders, especially small children, are clear of the working area.
2. Make sure there is enough room and clearance to safely back up to the 3-Plex Land Roller.
3. Use the Jack to move the hitch to the required height.
4. Slowly back the tow vehicle until the clevis and hitch are aligned.



Fig. 20 Clear Working Area



Fig. 21 Aligning

5. Install the drawbar pin and the retainer.

### **IMPORTANT:**

Use a drawbar pin with provisions for a mechanical retainer. Always install the retainer.



Fig. 22 Drawbar Pin and Retainer

6. Attach the safety chain around the drawbar cage to prevent unexpected separation.



Fig. 23 Safety Chain

## 3.6 CONNECT THE HYDRAULIC AND ELECTRICAL SYSTEM



**WARNING:** High Pressure Fluid  
Wear eye and hand protection when searching for leaks. Relieve pressure before adjusting. Keep components in good repair.

1. Use a clean cloth or paper towel to clean the dirt and build-up from around the hydraulic couplers/male tips.
2. Ensure the hydraulic hoses are properly routed through the Hydraulic Hose Retainer on the Hitch to prevent the hoses from dragging on the ground.
3. Insert the hydraulic couplers/male tips into the hydraulic ports on the tractor. Be sure they are locked in place. Ensure all hydraulic circuits are routed properly, handles are color coordinated for your convenience.
4. Connect the wiring harness to the tractor if transporting on a public road. Be sure the wiring harness is properly routed through the Hydraulic Hose Retainer to prevent it from dragging on the ground.

**IMPORTANT:**  
It is recommended that extra lights and pilot vehicles be used during times of limited light or visibility.
5. Insert plug into Hydraulic Storage Plate when not in use. See Fig. 16
6. Insert hydraulic couplers/male tips into Hydraulic Storage Plate when not in use. See Fig. 16
7. Retract the Jack.
  - Pull out the pin
  - Rotate 90° and store in stowed position.
  - Install the pin.

Reverse the above procedures when unhooking from the tractor.



Fig. 24 Hydraulic Hose and Plug Storage Holder



Fig. 25 Hydraulic Circuits Installed



Fig. 26 Wiring Harness



Fig. 27 Jack Stowed

## 3.7 FIELD OPERATION

The 3-Plex Land Roller is easy to use. Still, each operator should review this manual to familiarize themselves with the Safety and Operating procedures.

When using this machine, follow this procedure:

1. Clear the area of bystanders, especially small children.
2. Attach the machine to the tractor. See Section 3.5
3. Check the unit to be sure it is level and set.
4. Transport to the working area.
5. Convert to field position. See Section 3.8

### 3:7:1 STARTING:

With the tractor engine at approximately 1/3 throttle position, release the clutch and move forward. Increase throttle position until desired engine RPM is reached.

### 3:7:2 STOPPING:

Reduce engine RPM and press clutch to stop machine.

### 3:7:3 ROLLER WEIGHT:

Rollers are hollow and equipped with a Bung. Water may be added to the roller to increase its weight. This is helpful for rolling pasture land or an area with heavy plant growth.

#### IMPORTANT:

The axle assembly and frame on a 3-Plex Land Roller are not designed to lift and carry more weight than the base unit. Ensure the rollers are drained of liquid before folding the frame and transporting.



Fig. 31 Machine



Fig. 28 Enroute to Field



Fig. 29 Field Position



Fig. 30 Roller Bung



**ATTENTION: Equipment Damage Imminent**  
Always remove fluid from rollers before folding frame, lifting the 3-Plex Land Roller using its wheels or transporting.

### 3:7:4 BALLASTING:

Ballasting or adding weight to the 3-Plex Land Roller is optional for certain applications including, but are not limited to; forage crops, pasture and grazing land.

The extra weight assists in pushing over the plant material and contact the uneven ground surface features.

Normally water is used for ballast:

- Rotate unit, bringing the Bung to the top of the Roller Drum.
- Remove Bung and add water.
- Generally, filling 1/4 to 1/2 full provides sufficient extra weight for most applications.

**NOTE:**

On uneven terrain it is recommended to fill drum completely to increase stability and prevent weight shift.

**NOTE:**

Adding weight to the rollers substantially increases the weight of the machine. Increase the size of the tractor accordingly.

- Install and tighten the Bung.

To drain the ballast:

- Remove the Bung.
- Move roller to bring the Bung to the bottom.
- Allow water to drain fully.
- Rotate the machine to bring the Bung to top again.
- Install and tighten Bung.

### 3:7:5 SOIL MOISTURE:

Do not use the 3-Plex Land Roller to roll a field if the soil sticks together or adheres to the rollers. In addition to sticking to the rollers, wet conditions can cause the soil to form a crust on the surface of the field. This will prevent plant emergence.

Wait until the surface is dry before rolling.

**NOTE:**

Manufacturer will not be liable for damage caused by misuse of the machine.



Fig. 32 Ballasting



Fig. 33 Roller Bung



Fig. 34 Sticky Soil

### 3:7:6 HITCH TYPE:

The 3-Plex Land Roller is equipped with a Category 3 Pintle Hitch, installed at the factory.

An optional Clevis hitch attachment is available. It mounts to the bottom of the hitch and allows the 3-Plex Land Roller to be attached to a tractor with an alternate hitch.

Be sure to match the machine and tractor hitches before attaching to the tractor and moving the machine.



Fig. 35 Pintle/Clevis Hitch

### 3:7:7 HITCH HEIGHT:

The height of the Pintle Hitch can be adjusted by the clevis mounting position on the front of the hitch frame.

Use the jack to match the machine hitch height to the tractor hitch or use the hitch cylinders to raise or lower as required when hooking up.



Fig. 36 Hitch Height: Jack/Pintle Mount

### 3:7:8 TRAVEL SPEED:

The operator must determine the appropriate speed for the terrain and field conditions. It is not recommended to travel faster than 10 km/h (6 mph) in the field to prevent bouncing.

Slow down for rough, hilly or rolling terrain. To be effective, the rollers must keep contact with the ground during operation. Select a speed that will keep the 3-Plex Land Roller operating properly.



Fig. 37 Travel Speed

### 3:7:9 TURNING (CORNERING) SPEED:

It is recommended that the speed be reduced by half when approaching the end of the field, or a corner. By slowing to half speed or less, the roller will be more controllable.

If the terrain results in the turn taking place while going down-hill, you must slow down well before the turn.

**Note:**

Slowing down ensures control is maintained. This prevents pushing the tractor into a jackknife condition. Particularly important in hard soil conditions.

Slowing down before turning allows the driver to better judge what distance the outer end of the roller is from the end of the field or corner.

**Note:**

Misjudging the distance can result in hitting an obstacle at the end of the field. Do not take the chance.

### 3:7:10 OPERATING HINTS:

- Be sure there is sufficient clearance to fully extend the wings when changing configurations.

**IMPORTANT:**

Do not stand next to frame when pivoting to prevent pinching. Keep others away.

- When converting from transport to field configuration, fully engage Wing Lock Hooks when wheels are fully raised before starting to work. Completely retract Wing Lock Hooks before driving forward and folding wings.
- Remember: Do not back up with the 3-Plex Land Roller. It is designed to move forward only.



Fig. 38 Cornering



Fig. 39 Clearance



Fig. 40 Wing Lock Hooks: Engaged/Disengaged



- Raise machine into its fully raised position (wheels down) and install cylinder stops/transport lock brackets over the wheel lift cylinder rams before transporting. Close Hydraulic Ball Valves in the hitch and steering hydraulic circuit before transporting.
- Once Cylinder Stops have been installed and secured, release pressure from tractor to Lift Cylinders.



Fig. 41 Cylinder Stops Installed

- When ballasting the machine, bring water truck to the field.
  - Add water to the rollers.
  - Level field.
  - Drain water before leaving the field.



**ATTENTION: Equipment Damage Imminent**  
Always remove fluid from Roller Drums before folding frame, lifting the 3-Plex Land Roller using its wheels or transporting.

- Remember: It is not recommended to back up with the machine. It is designed to move forward only.



Fig. 42 Hydraulic Ball Valves: Hitch, Steering

## 3.8 TRANSPORT TO FIELD CONVERSION

The 3-Plex Land Roller is designed to be easily converted from transport to field configuration with minimal effort.

Follow this procedure:

1. Transport the 3-Plex Land Roller to the field where it will be used.
2. Stop the machine in an open area with sufficient space to unfold the Right and Left Wings.
3. Clear the area of bystanders, especially small children.
4. Raise the machine into its fully raised position (wheels down) to relieve the pressure from the Cylinder Stops.
5. Remove all Cylinder Stops from off the Wheel Lift Cylinders on both Center Section Wheel Assemblies, Left and Right Wing Wheel Assemblies.
6. Store Cylinder Stops on Storage Rod Holder located on the Center Section.
7. Open Hydraulic Ball Valves in the Hitch and Steering circuits.



Fig. 43 Center Section Cylinder Stop: Installed/Removed



Fig. 44 Wing Cylinder Stop: Installed/Removed



Fig. 45 Cylinder Stops Stored



Fig. 46 Hitch Circuit Hydraulic Ball Valves: Closed/Open



Fig. 47 Steering Circuit Hydraulic Ball Valves: Closed/Open

- Using the steering hydraulic circuit turn the rear wheels outward to assist in unfolding the Left and Right Wings into field configuration.



Fig. 48 Steerable Wheels: Straight/Turned

- Back up the machine to begin unfolding the Left and Right Wings.



Fig. 49 Enroute to field position

- Continue to back up until all Roller Drums are parallel, right angles from the direction of travel and the Wing Lock Hooks are in position to be engaged.



Fig. 50 Roller Drums at right angles from the direction of travel

11. Using the Wing Lock Hook Circuit, engage Wing Lock Hooks.

**IMPORTANT:**

All frames must be completely parallel in order to allow both Wing Lock Hooks to engage. Ensure both Wing Lock Hooks are fully engaged before moving forward.



Fig. 51 Wing Lock Hooks: Disengaged/Engaged

12. Using the Wheel Lift Circuit, raise all Wheel Assemblies until they are in the fully raised position.



Fig. 52 Wheel Assmeblies: Raising/Raised

13. Place Hitch Hydraulic Circuit into Float position allowing the hitch to move freely with the ground contour.
14. Reverse this procedure when converting from field to transport configuration.

### 3.9 TRANSPORTING

The Mandako 3-Plex Land Rollers are designed to be easily and conveniently moved from place to place. When transporting, follow this procedure:

1. Clear the area of bystanders, especially small children.
2. Ensure that the 3-Plex Land Roller is properly hitched to the tow vehicle. (See Section 3.5)
3. Convert to Transport Mode.  
-If the 3-Plex Land Roller is in field mode convert into transport configuration by reversing the procedures in the Transport to Field Conversion Section 3.8
4. Install Cylinder Stops over the rams of the Wheel Lift Cylinders.  
-If the Cylinder Stops have not yet been installed, remove Cylinder Stops from Storage Rod Holder and properly install them.
5. Release pressure from the Wheel Lift Hydraulic Circuit.  
-Using the Wheel Lift Hydraulic Circuit release the pressure to the Wheel Lift Cylinders releasing the weight of the machine off the Wheel Lift Cylinder and onto the Cylinder Stops.



Fig. 53 Field Mode



Fig. 54 Transport Mode



Fig. 55 Center Section Cylinder Stop: Removed/Installed



Fig. 56 Wing Section Cylinder Stop: Removed/Installed

6. Adjust Hitch Level.

- Using the Hitch Hydraulic Circuit, function the hitch cylinders till the Main Section is close to level.
- Once the Main Section is level close the Hydraulic Ball Valves on the Hitch Circuit.



Fig. 57 Hitch Circuit Hydraulic Ball Valves: Open/Closed

7. Ensure Steering Wheels are turned straight.

- Using the Steering Hydraulic Circuit, function the steering cylinders to make sure the wheels are turned completely straight
- Once the Steering Wheels are straight close the Hydraulic Ball Valves on the Hitch Circuit.



Fig. 58 Steerable Wheels: Turned/Straight

8. Keep to the right and yield right-of-way to allow faster traffic to pass. Drive on the road shoulder, if permitted by law.

9. Make sure the SMV (Slow Moving Vehicle) emblem, all lights and reflectors, that are required by local highway and transport authorities, are in place. Check that they are clean and can be seen clearly by all overtaking and oncoming traffic.

10. It is not recommended that the machine be transported faster than 20 mph (32 kph). Table 2 gives the acceptable transport speed as the ratio of tractor weight to roller weight.



Fig. 59 Steering Circuit Hydraulic Ball Valves: Open/Closed

Road Speed	Weight of Fully Equipped or Loaded Implement(s) relative to weight of tow vehicle
Up to 20 mph (32 kph)	1 to 1, or less
Up to 10 mph (16 kph)	2 to 1, or less
Do not tow	More than 2 to 1

Table 2 - Travel Speed vs Weight

11. Do not allow riders on the machine.

12. Always use hazard flashers on the tractor when transporting unless prohibited by law.

13. During periods of limited visibility, use pilot vehicles and use extra lights on the machine.



Fig. 60 Lights and SMV in place and clear to see

### 3.10 STORAGE

#### 3:10:1 PLACE IN STORAGE:

At the end of the season, the machine should be thoroughly inspected and prepared for storage. Repair or replace any worn or damaged components to prevent unnecessary down time at the beginning of the next season.

Follow this procedure before storing:

1. Remove all entangled material.
2. Thoroughly wash the unit with a pressure washer or water hose to remove all dirt, mud or debris.
3. Lubricate all grease points as per Section 4. Ensure all grease cavities are full to remove any water residue from washing.
4. Inspect all hydraulic hoses, couplers and fittings. Tighten any loose fittings. Replace any hose that is badly cut, nicked, abraded or is separating from the crimped end of a fitting.
5. Touch up all paint nicks and scratches to prevent rusting.
6. Select an area that is dry, level and free of debris.
7. Move the machine to its storage area.
8. Place the machine into its transport configuration. Relieve the pressure from off the Wheel Lift Cylinder and onto the Cylinder Stops  
or  
rest the Roller Drums on the ground in field configuration to relieve the pressure in the hydraulic circuit.

**NOTE:**

Life expectancy of the cylinders is increased when cylinder rams are retracted. Extended rams over a long period of times can cause rust and pitting on the cylinder rams.

9. Place planks under the jack for added support if required.
10. Unhook the machine from the tractor.  
(See Section 3.5)
11. Apply a rust inhibitor or heavy grease to the exposed hydraulic cylinder rams to prevent rusting.



Fig. 61 Clean Roller

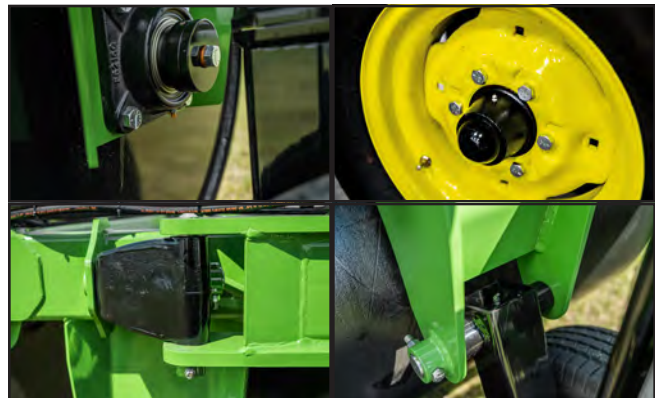

Fig. 62 Lubricate Equipment



Fig. 63 Store Equipment

**IMPORTANT:**

Remove inhibitor or grease before using machine again.

### 3:10:2 REMOVE FROM STORAGE:

When removing this machine from storage, follow this procedure:

1. Clear the area of bystanders, especially small children.
2. Attach the machine to the tractor (See Section 3.5).
3. Check the following:
  - Electrical harness connections and components.
  - All hardware. Tighten as required.
  - Tire pressure.
  - All hydraulic lines, fittings and connections. Tighten as required.
4. Lubricate grease fittings as per Section 4
5. Clean rust inhibitor or grease from exposed cylinder ram ends.
6. Replace any worn or defective parts.
7. Go through the Pre-Operation Checklist before using machine. (See Section 3.3)

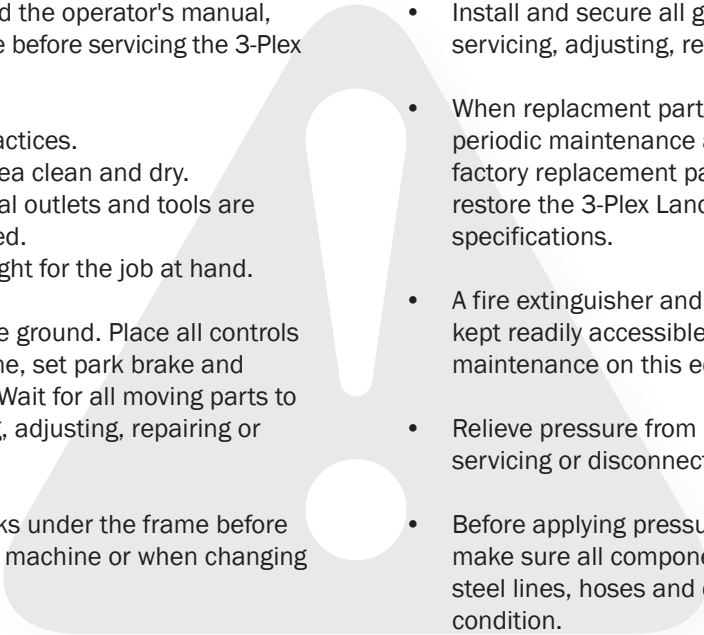

Fig. 64 Stored Equipment



Page intentionally left blank

## Section 4: SERVICE AND MAINTENANCE

- 
- Read and understand the operator's manual, and all safety signage before servicing the 3-Plex Land Roller.
  - Follow good shop practices.
    - Keep service area clean and dry.
    - Be sure electrical outlets and tools are properly grounded.
    - Use adequate light for the job at hand.
  - Lower machine to the ground. Place all controls in neutral, stop engine, set park brake and remove ignition key. Wait for all moving parts to stop before servicing, adjusting, repairing or unplugging.
  - Place stands or blocks under the frame before working beneath the machine or when changing tires.
  - Always use personal protective equipment such as safety glasses, gloves and hearing protection, when performing any service or maintenance work.
  - Install and secure all guards and shields before servicing, adjusting, repairing or unplugging.
  - When replacement parts are necessary for periodic maintenance and servicing, genuine factory replacement parts must be used to restore the 3-Plex Land Roller to its original specifications.
  - A fire extinguisher and first aid kit should be kept readily accessible while performing maintenance on this equipment.
  - Relieve pressure from hydraulic system before servicing or disconnecting from tractor.
  - Before applying pressure to a hydraulic circuit, make sure all components are tight, and that steel lines, hoses and couplings are in good condition.
  - When completing a maintenance or service function, make sure all safety shields and devices are installed before beginning to operate the unit.

---

### 4.1 FLUIDS AND LUBRICANTS

#### 4:1:1 GREASE:

Use an SAE multipurpose high temperature grease with extreme pressure (EP) performance. Also acceptable is an SAE multipurpose lithium base grease.

#### 4:1:2 STORING LUBRICANTS:

Your machine can operate at top efficiency only if clean lubricants are used. Use clean containers to handle all lubricants. Store them in an area protected from dust, moisture and other contaminants.

#### 4:1:3 GREASING:

Refer to Section 4.1.1 for the type of recommended grease.

Use the Maintenance Checklist provided to keep a record of all scheduled maintenance.

1. Use a hand-held grease gun for all greasing.
2. Wipe grease fitting with a clean cloth before greasing, to avoid injecting dirt and grit.
3. Replace and repair broken fittings immediately.
4. If fittings will not take grease, remove and clean thoroughly. Also, clean lubricant passageway. Replace fittings if necessary.

## 4.2 SERVICING INTERVALS

The periods recommended are based on normal operating conditions. Severe or unusual conditions may require more frequent checks of the equipment and lubrication.

### 4:2:1 EVERY 10 HOURS OR DAILY:

1. Check machine for worn or damaged parts.
2. Check the machine for any hydraulic fluid leaks.
3. Grease the Wing Hinge Knuckles with 6 shots of grease or until grease begins pressing out of the sides. (4 grease points)

### 4:2:2 MONTHLY OR EVERY 1000 ACRES:

4. Grease the Wing Lock Hooks with 3 shots of grease each or until grease begins pressing out of the sides. (2 grease points)

5. Grease Center Section Axle Arms with 6 shots of grease or until grease begins pressing out of the sides. (2 grease points)

6. Grease Wing Section Steering Axle Assemblies. Grease all locations with 3-6 shots of grease or until grease begins pressing out of the side. (10 grease points)

7. Check tire pressure. See section 7 for tire specs.



Fig. 65 Knuckle



Fig. 66 Wing Lock Hook



Fig. 67 Center Section Axle Arm



Fig. 68 Steering Axle Assemblies

### 4:2:3 ANNUALLY OR EVERY 3000 ACRES:

8. Grease the Hitch Jack with 2 shots of grease. (1 grease point)



Fig. 69 Hitch Jack

9. Grease all Roller Drum bearings with 1 shot of grease each. (6 grease points)

#### **IMPORTANT:**

The 3-Plex Land Roller is designed with sealed bearings on the Roller Drums. **DO NOT OVER GREASE!** Over greasing will destroy the seal and minimize the life of the bearing.



Fig. 70 Roller Drum Bearings

10. Grease all wheel hubs.
  - Remove plug and insert grease zerk located in the Operators Manual Cannister.
  - Grease with one shot of grease for each wheel hub. (8 grease points)

#### **NOTE:**

Rebuild wheel hubs every 3 years.

- Dissassemble
- Clean
- Inspect all bearings, races, seals and other parts
- Replace worn or damaged parts
- Repack with fresh grease
- Assemble

#### **IMPORTANT:**

The 3-Plex Land Roller is designed with sealed wheel hubs. **DO NOT OVER GREASE!** Over greasing will destroy the seal and minimize the life of the wheel bearings.

11. Clean and wash machine.



Fig. 71 Wheel Hubs: Plug/Zerk

### 4.3 SERVICE RECORD

The Servicing Intervals section is only a guide under good conditions. Under extreme, or unusual circumstances adjust service timing accordingly.

Copy this page to continue record.

Maintenance	Date																		
	Serviced By																		
EVERY 10 HOURS OR DAILY																			
Check for worn or damaged parts																			
Check for hydraulic leaks																			
Grease Wing Hinge Knuckles																			
MONTHLY OR EVERY 1000 ACRES																			
Grease Wing Lock Hooks																			
Grease Axle Arms																			
Grease Steering Axle Assemblies																			
Check Tire Pressure																			
ANNUALLY OR EVERY 3000 ACRES																			
Grease Hitch Jack																			
Grease Roller Drum Bearings																			
Grease Wheel Hubs																			
Clean and Wash Machine																			

# Section 5: TROUBLE SHOOTING

This Land Roller is a simple and reliable system that requires minimal maintenance.

The problems which you may encounter, their causes and solutions, are listed below.

If you encounter a problem which is difficult to solve, even after having read through this section, please contact your local distributor or dealer. Before you call, please have this Operator's Manual and the unit's serial number ready.

### ***Problem***

Possible Cause	Possible Solution
----------------	-------------------

### ***Settling of implement from raised position***

Leaking wheel cylinder	Replace cylinder seals
Leaking tractor hydraulic control valve	Repair tractor
Spongy hydraulics or inconsistent motion	Bleed hydraulic lines
Wheel wobble, noise or vibrations	Rebuild wheel hub
Hydraulics not functioning after extended time stored	Relieve pressure in hydraulic lines

Page intentionally left blank

## Section 6: SIGN-OFF FORM

Mandako Agri Marketing (2010) Ltd. follows the general Safety Standards specified by the American Society of Agricultural Engineers (ASAE), and the Occupational Safety and Health Administration (OSHA). Anyone who will be operating and/or maintaining the unit must read and clearly understand all Safety, Operating and Maintenance information presented in this manual.

Do not operate, or allow anyone else to operate, this equipment until this document has been read. Review this information annually, before the season start-up.

Make periodic reviews of SAFETY and OPERATION a standard practice for all of your equipment.

The following Sign-Off Form is provided for your record keeping. Use it to show that all personnel who will be working with the equipment have read and understand the provided information. They also have been instructed in the operation of the equipment. Copy this page to continue the record.

DATE	EMPLOYEE'S SIGNATURE	EMPLOYER'S SIGNATURE



## Sign Off Form (Continued)

<b>DATE</b>	<b>EMPLOYEE'S SIGNATURE</b>	<b>EMPLOYER'S SIGNATURE</b>

## Section 7: REFERENCE

For information not included here, or for a digital copy of this manual, please call your dealer, or Mandako directly for assistance (1-888-525-5892).

Specifications may change without notice.

### 7.1 BOLT TORQUE

#### CHECKING BOLT TORQUE

The tables shown below give correct torque values for various bolts and capscrews. Tighten all bolts to the torques specified in chart unless otherwise noted. Check tightness of bolts periodically, using bolt torque chart as a guide. Replace hardware with the same strength bolt.

Bolt Diameter "A"	Bolt Torque •					
	SAE 2 (N.m) (lb-ft)		SAE 5 (N.m) (lb-ft)		SAE 8 (N.m) (lb-ft)	
1/4"	8	6	12	9	7	12
5/16"	13	10	25	19	36	27
3/8"	27	20	45	33	63	45
7/16"	41	30	72	53	100	75
1/2"	61	45	110	80	155	115
9/16"	95	60	155	115	220	165
5/8"	128	95	215	160	305	220
3/4"	225	165	390	290	540	400
7/8"	230	170	570	420	880	650
1"	345	225	850	630	1320	970
1-1/8"	651	480	1077	794	1939	1430
1-1/4"	508	375	1498	1105	2678	1975

Wheel hub lug bolts should be torqued to 103 lb-ft.

Torque figures indicated above are valid for non-greased or non-oiled threads and heads unless otherwise specified. Therefore, do not grease or oil bolts or capscrews unless otherwise specified in this manual. When using locking elements, increase torque values by 5%.

- Torque value for bolts and capscrews are identified by their head markings.

### 7.2 TIRE PRESSURE

The recommended tire pressure is specific to the tires on your machine. Match your tires to the table below to find the right tire pressure for your tire. Never exceed the manufacturers maximum tire pressure rating!

Goodyear (235/80 R16)	65-70 PSI
Provider (235/80 R16)	65-70 PSI

### 7.3 HYDRAULIC FITTING TORQUE

Tightening Flare Type Tube Fittings\*

1. Check flare and flare seat for defects that might cause leakage.
  2. Align tube with fitting before tightening.
  3. Lubricate connection and hand tighten swivel nut until snug.
  4. To prevent twisting the tube(s), use two wrenches on the connector body and with the second tighten the swivel nut to the torque shown.
- The torque values shown are based on lubricated connections as in reassembly.

Pipe Rigid - Tapered Pipe Threads (NPTF, N/NF) - Carbon Steel			
Pipe Size	Turns-from-finger	Max ft-lbs	Max N-m
1/8" (-2)	3/4 - 1 3/4	12	16
1/4" (-4)	3/4 - 1 3/4	25	34
3/8" (-6)	3/4 - 1 3/4	40	54
1/2" (-8)	1/2 - 1 1/2	54	73
3/4" (-12)	1/2 - 1 1/2	78	106
1" (-16)	1/2 - 1 1/2	112	152
1 1/4" (-20)	1/2 - 1 1/2	154	209
1 1/2" (-24)	1/2 - 1 1/2	211	286
2" (-32)	1/2 - 1 1/2	300	407
For reference only, Source: Air-Way Manufacturing Co. - Carbon Steel Hydraulic			

Stud End O-Ring Boss (ORB) SAE (U/UF)			
		Carbon Steel	
Tube Size	Thread UNF-2A	Max ft-lbs	Max N-m
-2	5/16" - 24	6-7	8-9
-3	3/8" - 24	8-9	11-12
-4	7/16" - 20	13-15	18-20
-5	1/2" - 20	17-19	23-26
-6	9/16" - 18	22-24	29-33
-8	3/4" - 16	40-43	49-53
-10	7/8" - 14	43-48	59-64
-12	1 1/16" - 12	68-75	93-102
-14	1 3/16" - 12	90-99	122-134
-16	1 5/16" - 12	112-123	151-166
-20	1 5/8" - 12	146-161	198-218
-24	1 7/8" - 12	154-170	209-231
For reference only, Source: Air-Way Manufacturing Co. - Carbon Steel Hydraulic			

O-Ring Face Seal Fitting (ORFS) (F/FF)			
Tube Size	Turns-from-finger	Torque ft-lbs	Torque N-m
-4	9/16 - 18	10-12	14-16
-6	11/16 - 18	18-20	24-27
-8	13/16 - 16	32-35	43-47
-10	1 - 14	46-50	60-68
-12	1 3/16 - 12	65-70	90-95
-16	1 7/16 - 12	92-100	125-135
-20	1 11/16 - 12	125-140	170-190
-24	2 - 12	150-165	200-225
For reference only, Source: Air-Way Manufacturing Co. - Carbon Steel Hydraulic			

7.4 MECHANICAL SPECIFICATIONS

# 3-PLEX LAND ROLLER SPECIFICATIONS

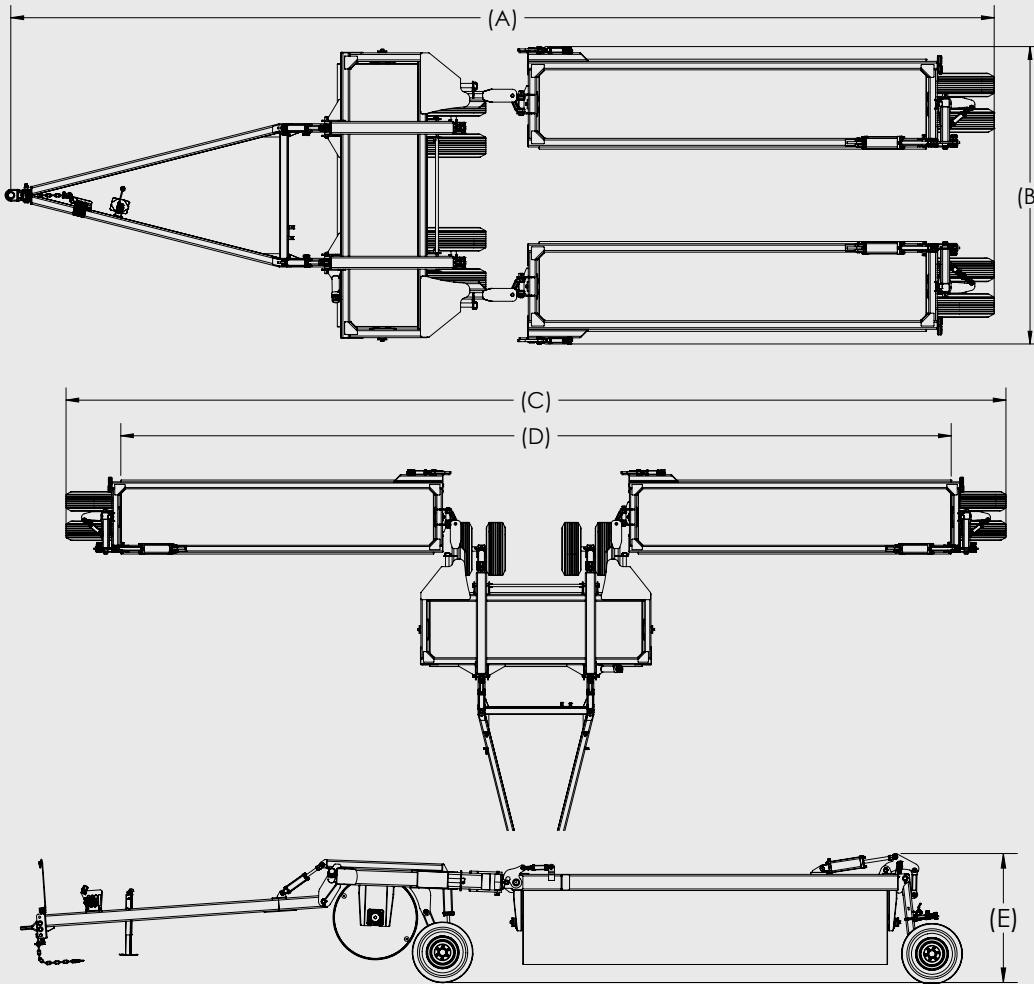

	Unit Size					
Dimension	30'	34'	40'	42'	45'	50'
Transport Length (A)	34'	36'	39'	40'	41'-6"	44'
Transport Width (B)	11'-7"	11'-7"	11'-7"	11'-7"	11'-7"	11'-7"
Overall Width (C)	33'-6"	37'-6"	43'-6"	45'-6"	48'-6"	53'-6"
Working Width (D)	30'	34'	40'	42'	45'	50'
Overall Height (E)	5'-5"	5'-5"	5'-5"	5'-5"	5'-5"	5'-5"
Hyd. Req. (@2800PSI)	5 GPM (19 LPM)	5 GPM (19 LPM)	5 GPM (19 LPM)	5 GPM (19 LPM)	5 GPM (19 LPM)	5 GPM (19 LPM)
Hyd. Req. (Ports)	3	3	3	3	3	3
Horsepower Req.	120+	136+	160+	168+	180+	200+
Approx. Weight (lbs/ft) 42" x 5/8" Drum	530	507	495	488	469	465
Drum Size	36" x 1/2" W   42" x 5/8" W   42" x 3/4" W					
Tire Size	ST235/80R16E 10 Ply	ST235/80R16E 10 Ply	ST235/80R16E 10 Ply	ST235/80R16E 10 Ply	ST235/80R16E 10 Ply	ST235/80R16E 10 Ply



REVISION: 1.0

**PART #: R9912004-01**

**RELEASED: MARCH 01, 2020**

Box 379 | 12159B Hwy 306

Plum Coulee, MB R0G 1R0

(888) 525-5892

info@mandako.com

www.mandako.com

**MANDAKO AGRI MARKETING (2010) LTD.**



Printed in Canada